

Material: PVC / PPs / PP / PE

Saddle for welding
prepared for pipe Do Ø

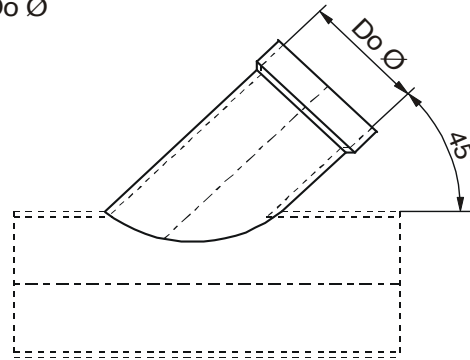

Endcap

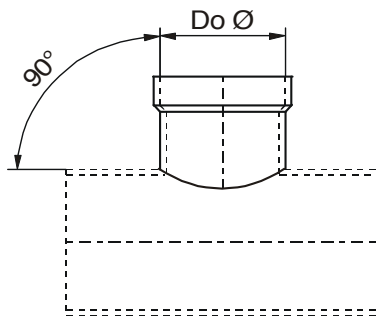
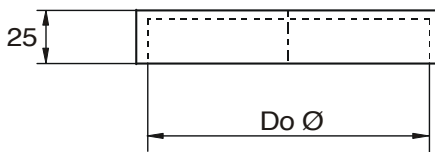

Flexible PVC ducting

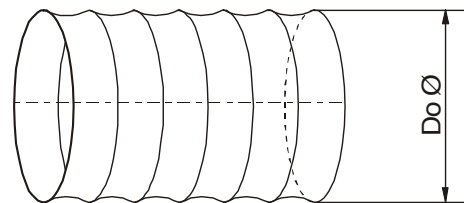

pipe from sheet material

Do Ø	Standardlength/m	Section = S mm					
450	L = 3 m	5 mm					
500	L = 3 m	5 mm	6 mm				
560	L = 3 m	5 mm	6 mm				
600	L = 3 m	5 mm	6 mm				
630	L = 3 m	5 mm	6 mm				
700	L = 3 m		6 mm	8 mm			
710	L = 3 m		6 mm	8 mm			
800	L = 3 m			8 mm	10 mm		
900	L = 3 m			8 mm	10 mm	12 mm	
1000	L = 3 m				10 mm	12 mm	
1250	L = 3 m					12 mm	15 mm
1400	L = 3 m					12 mm	15 mm

different sizes upon request

all dimension in mm

prices are on page 22, 23 and 24

We reserve the right to change dimension and design !